



PHONE: (989) 435-7080

3195 LYLE ROAD • BEAVERTON, MI 48612
www.howeracing.com

FAX: (888) 484-3946

Instructions to Replace the Seals in a Howe G3 Master Cylinder

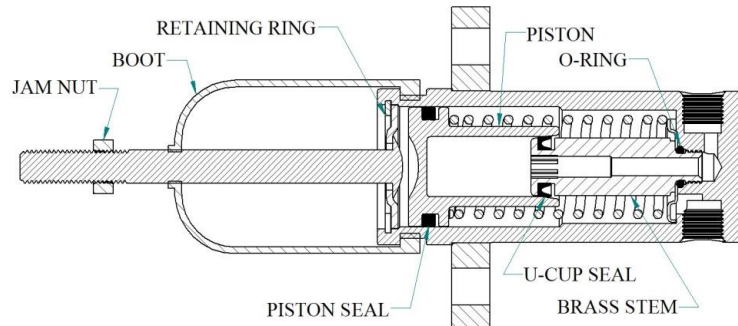

Provided in Kit:

ASSEMBLY LUBRICANT
PLASTIC PICK
SEAL INSTALLATION BULLET
PISTON SEAL

U-CUP SEAL
O-RING SEAL, STEM

Required Tools:

RETAINING RING PLIERS
3/16" HEX T HANDLE
SHOP TOWELS

⇨ **EXTREMELY IMPORTANT!** ⇩

- Due to the critical function of brakes, you must perform these steps exactly as described. If you have any doubts, replace the entire master cylinder or send it to us for a factory rebuild.
- Never use Castrol SRF or ATE Super Blue brake fluid as they are known to swell and deteriorate the seals. Approved are: Motul RBF600, AP Super 600, Stop Tech STR600, Wilwood 570.
- Do not use metal tools for removing seals as they will scratch sealing surface.
- Seals are not compatible with petroleum cleaners.

Disassembly:

- 1) Remove the jam nut from push rod and remove the boot.
- 2) Caution! Parts under the retaining ring are spring loaded.
- 3) Use the retaining ring pliers to remove retaining ring.
- 4) Remove the brass stem by turning counter clockwise using a 3/16" hex T handle,
- 5) Using the plastic pick, remove from the brass stem, first the o-ring then the u-cup seal.

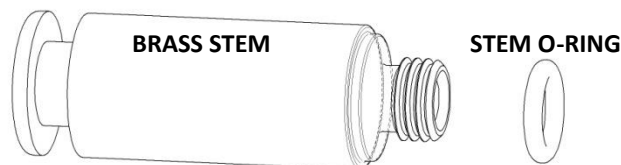

Assembly:

- 1) Inspect all bore and piston surfaces for scratches, these can be caused from disassembly or fluid contamination. Do not reuse damaged parts. Wipe all parts clean with a new shop towel.

- 2) By hand, work o-ring over threads of brass stem into groove.
- 3) Using supplied lube, apply a small amount to the supplied seal installation bullet.
- 4) Noting the orientation, slide the u-cup seal over the bullet and into the seal groove on brass stem being very careful not to roll or twist the seal.

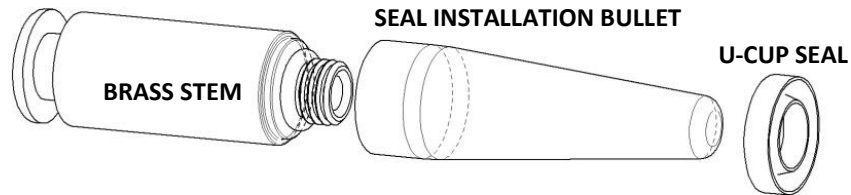

- 5) In the bottom of the bore is the base washer, it may or may not have come out with stem removal. The base washer has a groove on one face and a flat on the outside edge. Using the 3/16 hex T-handle, install the brass stem into the housing by turning clockwise. Verify that the base washer is at the bottom of the bore has the face groove side toward the bottom of the bore and the flat on the outside edge up, toward the "IN" port side of the housing.

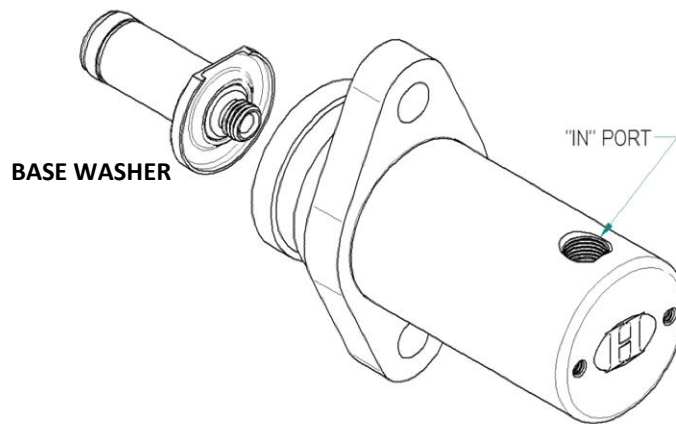

- 6) Install piston seal onto piston by hand. **MAKE SURE THE SEAL IS NOT TWISTED IN THE GROOVE!**
- 7) Apply supplied assembly lubricant to the bore and piston seal.
- 8) Install the spring into bore and the piston into the spring.
- 9) Push the piston/spring assembly into the housing with the push rod and push rod washer.
- 10) Install the retaining ring by using the retaining ring pliers.
- 11) Install the boot by hand.
- 12) Install jam nut on the push rod.

